

# rotork®

Keeping the World Flowing  
for Future Generations

IQ Range  

IQ & IQT Electric Valve Actuators including Stayput Safety Function  
**SAFETY MANUAL**

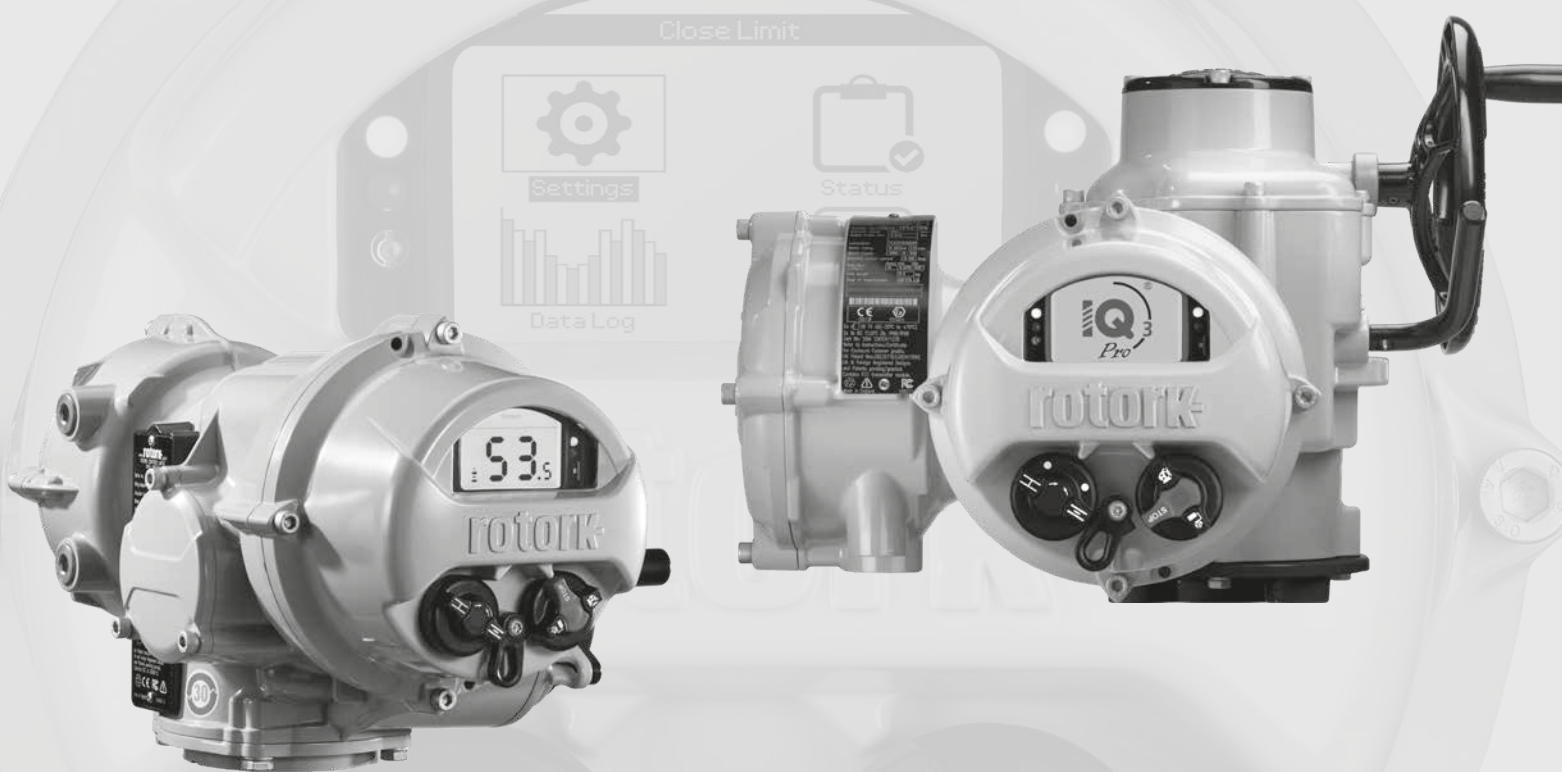

IQ3 and IQ3 Pro Multi-turn and Part-Turn Electric Valve Actuators



## Table of Contents

<b>1. Overview</b>	<b>3</b>
1.1 Overview of Equipment Covered by the Functional Safety Assessment	4
1.2 Safety Manual Overview	4
1.3 Safety Functions	5
1.4 Applicable Actuator Types	5
1.5 IQ Stayput Safety Function Option – Actuator Reliability Data	6
1.6 Safety Function 1 – Stayput: Motor Enable Operating Principle	6
<b>2. Safety Function Operation</b>	<b>7</b>
2.1 Safety Function 1 – Stayput Operation	7
<b>3. Design Requirements</b>	<b>8</b>
3.1 Actuator Selection and Sizing	8
3.2 Valve Loading	8
3.3 Actuator Power	9
3.4 Actuator Control	9
3.5 Actuator Indication	10
3.6 Environmental	10
3.7 Safety Instrumented System (SIS) Assessment for SIL 2 and SIL 3 Applications	11
<b>4. Installation</b>	<b>12</b>
4.1 Important Information	12
4.2 Basic Commissioning – Valve Settings	13
4.3 Basic Settings – Limits	16
4.4 Close Settings	16
4.5 Open Settings	17
4.6 Breakout Torque	17
4.7 Secondary Settings – Remote Maintain (SF1 only)	18
<b>5. Verification</b>	<b>19</b>
5.1 Valve Setting Verification	19
5.2 Safety Function 1 – Stayput Verification	20
<b>6. Tamper Prevention</b>	<b>20</b>
<b>7. General Maintenance</b>	<b>21</b>

## 1. Overview

### Actuator Safety Manual

**⚠** This safety manual defines the setup, installation, operation and maintenance of IQ3, IQT3, IQ3 Pro and IQT3 Pro actuators including the Stayput Safety Function, designed for Safety Instrumented Systems requiring Functional Safety Integrity Levels (SIL) 2 or SIL 3 to Standard IEC61508-2:2010.

#### Applicable Safety Functions:

1. **Stayput** - not to move spuriously.  
Also known as Motor Enable (permissive)

SIRA Functional Safety Approval Certificate:  
SIRA FSP 15001 and 16009

**⚠ WARNING: Failure to apply the procedures detailed in this manual will invalidate the safety function certification.**

**⚠ WARNING: This Safety Manual must be read and implemented in conjunction with PUB002-039 (IQ3 and IQ3 Pro) or PUB002-065 (IQT3 and IQT3 Pro) Safe Use, Installation and Maintenance manuals.**

#### Glossary:

SIL	Safety Integrity Level
SIS	Safety Instrumented System
Stayput	Remain in place or Do Not Move
SF1	Safety Function 1 (Stayput)
PFD	Probability of Failure on Demand
MTTR	Mean Time to Repair
DCS	Distributed Control System
PLC	Programmable Logic Controller
PFH	Probability of failure per hour
SC2	Systematic Capability 2 (for use with SIL2 equipment)
SC3	Systematic Capability 3 (for use with SIL3 equipment)

## 1.1 Overview of Equipment Covered by the Functional Safety Assessment

---

The IQ range is a family of electric valve actuators categorised by output torque and speed at a specified supply voltage, designed to provide local and remote operation of industrial valves and dampers of all types. This safety manual is applicable only to IQ3, IQT3, IQ3 Pro and IQT3 Pro actuators with Stayput Safety Function.

As well as providing normal process control of valves, remote control may include Emergency Shut Down (ESD) operation to open or close a valve or a Motor Enable input to ensure a valve does not move spuriously, as a priority.

The IQ range design consists of a gear case enclosure and electrical covers, cast in aluminium alloy, which are bolted to a cast iron base providing connection to the valve or gearbox. Output movement is derived from an electrical motor driving a worm and wheel gear running in an oil bath.

All IQ actuators include a hand/auto clutch engaged hand wheel for manual operation in case of loss of power supply and feature local and remote control selectors, *Bluetooth*<sup>®</sup> interface, position monitoring, torque sensing and control/indication I/O. Configuration of the actuator settings is provided via a high resolution LCD display and supplied proprietary Rotork *Bluetooth*<sup>®</sup> Setting Tool Pro.

IQ range actuators are designed to operate as standard between the temperature ranges of -30 to 70 °C. Low temperature options can also be offered down to -40 °C and all IQ actuators will have an enclosure rating to IEC60529 of IP66 and IP68 (7m for 72 hours). In addition, IQ can be provided with builds certified for use in hazardous areas under the ATEX directive, international Standard IEC Ex, North American NFPA –NEC and CSA standards (other national standard builds are also available).

The IQ3 and IQ3 Pro actuators applicable to the functional safety requirements of Stayput (Safety Function 1) shall be powered by a three-phase electrical supply only. The actuator must be powered for the Safety Function to be performed.

The IQT3 and IQT3 Pro actuators applicable to the functional safety requirements for Stayput (Safety Function 1) may be powered by a three-phase, single-phase or DC electrical supply. The actuator must be powered for the Safety Function to be performed.

Full description and specifications for IQ range actuators can be found in publication PUB002-038 (IQ3 and IQT3) and PUB002-197 (IQ3 Pro and IQT3 Pro).

## 1.2 Safety Manual Overview

---

This document is the Safety Manual for the IQ actuator, which can be identified and categorised by a specific wiring diagram to provide certified reliability for use in safety instrumented systems requiring SIL 2 or SIL 3 utilising the Motor Enable input. It contains detailed information on design requirements, installation, commissioning and verification of the actuator within the Safety Instrumented System (SIS) plus through-life and maintenance requirements. It also provides guidance on indication settings that may be used but are not part of the safety function of the actuator.

It is the responsibility of the user to determine whether the measures contained within this document are sufficient or necessary.

A list of documents applicable to SIRA assessment approval are listed on the SIL certificate FSP 15001 and 16009.

## 1.3 Safety Functions

The following safety function is available with actuators containing the Stayput Safety Function option (refer to actuator circuit diagram):

### Safety Function 1 - Stayput

- The actuator shall not move without a valid Motor Enable control signal combined with a valid remote Open, Close or ESD signal
- This is a high-demand mode safety function

## 1.4 Applicable Actuator Types

IQ and IQT actuators containing the Stayput Safety Function Control Board option only, designed for isolating or regulating valve duty with a SIS Safety Function 1 (Stayput) requirement. Mid-travel positioning is possible under normal operating conditions.

### Control

Safety Function 1 may only be implemented using hardwired signals within the range 16 - 60 VDC. Actuators may include control interface options for systems such as *Pakscan*<sup>™</sup>, Profibus<sup>®</sup>, Foundation Fieldbus<sup>®</sup> etc., however such systems do not fall within the scope of the safety functions applicable to this manual. Such control options may be used for process control/indication; however, Safety Function 1 can only be implemented by a hardwired Motor Enable signal.

### Indication

Monitor relay, "S" Contacts, CPT analogue position indication and those derived by network systems do not fall within the scope of the reliability given in this manual. For valve position indication required for the SIS, this must be derived directly from the valve stem (obturator) using certified contacts or other means. Such means do not fall within the scope of this safety manual.

Safety Function 1				
Type	Operation	Power supply	Duty rating	Starts /hr
IQ*	Multi-turn isolating & part-turn isolating	3-phase only	S2 / S2-25% Class A & B	60
IQT**	Part-turn isolating	3-phase, single phase, DC	S2 / S3 Class A & B	1200
IQTM**	Part-turn modulating	3-phase, single phase, DC	S4 / Class C	1800
IQTF**	Multi-turn modulating & Linear modulating	3-phase, single phase, DC	S4 / Class C	1800

\* Applicable to IQ3 and IQ3 Pro versions.

\*\* Applicable to IQT3 and IQT3 Pro versions.

## 1.5 IQ Stayput Safety Function Option – Actuator Reliability Data

The following reliability data covers the complete actuator up to and including the actuator output drive assembly. It does not include the valve, valve drive components or second stage gearboxes.

Reliability data shown below is the worst case example. For Safety Function 1 data, refer to SIRA certificate FSP 150001/02 and 16009.

## 1.6 Safety Function 1 – Stayput: Motor Enable Operating Principle

Safety Function 1 Stayput is high demand.

The Motor Enable signal input line is used to implement a control permissive. The design principle is therefore that the Motor Enable signal is applied ONLY when open or closed operation is authorised and intended. When operation is not authorised or intended (Stayput), the Motor Enable signal must be removed. It is at the discretion of the user as to whether the source (e.g. logic solver) of the Motor Enable signal is included in the SIS. De-energising the Motor Enable input line while the actuator is moving will cause the actuator to stop.

By controlling the Motor Enable input line, the user determines if and when control can take place. The Motor Enable input line may therefore be controlled from the Safety Instrumented System (SIS) logic solver while the remote control signals may be derived from the Basic Process Control System (BPCS).

The Motor Enable input line provides demonstrable reliability levels as assessed independently by SIRA and referenced in SIRA certificate FSP 150001 and 16009.

### IQ3 / IQ3 Pro:

Parameter	Size 1	Size 2	Size 3	Size 4	Size 5
<b>1oo1</b>					
Proof Test Interval (Hours)	8760	8760	8760	8760	8760
Type A/B	Type A	Type A	Type A	Type A	Type A
Safe Failure Fraction	93%	93%	93%	97%	97%
PFH	9.84E-07	9.84E-07	9.84E-07	9.28E-07	9.28E-07
SIL Capability (High/Continuous Demand Mode)	SIL2	SIL2	SIL2	SIL2	SIL2

### IQT3 / IQT3 Pro:

Parameter	Size 1	Size 2	Size 3	Size 4	Size 5
<b>1oo1</b>					
Proof Test Interval (Hours)	8760	8760	8760	8760	8760
Type A/B	Type A	Type A	Type A	Type A	Type A
Safe Failure Fraction	96%	96%	96%	96%	96%
PFH	4.46E-07	4.46E-07	4.46E-07	4.46E-07	4.46E-07
SIL Capability (High/Continuous Demand Mode)	SIL2	SIL2	SIL2	SIL2	SIL2

## 2. Safety Function Operation

### 2.1 Safety Function 1 – Stayput Operation

The table below provides an overview of the operating response of the IQ and IQT to local/remote control commands and the effect Motor Enable signal status has on their process operation.

SF1			
Control Mode	Applied Signal	Motor Enable Input	Action
Local	Open/Close	Applied	Local Operation
Local	Open/Close	Removed	Local Operation
Remote	Open/Close	Applied	Remote Operation
Remote	Open/Close	Removed	No Operation

Table 2.1

### 3. Design Requirements

---

#### 3.1 Actuator Selection and Sizing

---

The selection of actuator type and size is dependent on the valve type and its required operating forces (torque and/or thrust). It is the responsibility of the valve manufacturer/supplier to specify the required valve type and operating forces. For retrofit applications, it is the responsibility of the design engineer to specify the valve type and its operating forces. Actuator performance data is provided on the unit nameplate and on its individual test certificate.

The following selection and sizing design principles/conditions are applied and the installer must verify their suitability for the selected valve in performing its safety function within the SIS:

- Refer to essential health and safety information provided in PUB002-039 (IQ3 / IQ3 Pro) or PUB002-065 (IQT3 / IQT3 Pro).
- The supplied actuator has been sized based on its rated torque/thrust being at least equal to the required valve operating torque/thrust for the specified operating time.
- No additional safety factors have been added unless expressly requested.
- The actuator must only be fitted to the valve selected at the design stage.
- Changes in process conditions to those specified at the design stage may affect actuator sizing requirements and must be referred to the valve maker/supplier or design engineer.
- Valve operation under the specified process operating conditions must be verified.

**NOTE: The following design principles/conditions must be applied**

- The valve and/or valve motor components must be capable of safely withstanding the supplied actuator stall torque and/or developed thrust at stall torque.
- For design purposes, IQ stall torque shall be considered to be at least 2 times supplied actuator/actuator-gearbox combination rated torque.

#### 3.2 Valve Loading

---

The effect of valve loading does not fall within the scope of this safety manual. It is the responsibility of the SIS design engineer to verify that the valve load imposed on the actuator or actuator-gearbox combination is not capable of mechanically back driving it and therefore causing valve movement when the actuator is at rest. For linear gate valves, the stem thread lead efficiency must be sufficiently low to ensure a self-locking capability under worst case process conditions (thrust, temperature and pressure).

For part-turn valves with IQ + Gearbox combinations, including dampers, the efficiency of the worm gearbox should be sufficiently low to ensure the actuator cannot be back driven. Note that under vibration, no worm gear can be considered self-locking under all circumstances and a mechanical brake may be considered necessary.



### 3.3 Actuator Power

---

The actuator electrical power supply integrity does not fall within the scope of this safety manual. It is the responsibility of the SIS design engineer to ensure the integrity of the actuator power supply meets the requirements of the target SIL for the SIS. Electrical power is required for the safety function to be performed.

### 3.4 Actuator Control

---

Refer to the circuit diagram and control connection drawing supplied with the actuator.

In order to meet the requirements of SIL 2 for Safety Function 1, the actuator must be controlled for opening and closing using the appropriate control signal input and Motor Enable signal. The application of only the control signal is invalid and will display a "MOTOR ENABLE LOSS" alarm on the actuator.

Control signal integrity does not fall within the scope of the actuator reliability assessment. User must ensure the integrity of control signals meet the requirements of the target SIL for the SIS.

#### Network Option Control

If a network option field unit has been specified, (Modbus®, Profibus®, Foundation Fieldbus®, *Pakscan*™ etc.), the hardwired Motor Enable is intended to be operated by a logic solver that is part of the SIS.

#### Remote Hand Station

Although the Remote Hand Station is compatible with SIL, all SIL settings apply to the actuator only. Commissioning of SIL actuators can only be carried out local to the actuator.

### 3.5 Actuator Indication

---

#### Indication contacts

The actuator has four configurable contacts, S1 to S4 available for indication including Open and Closed position limit indication and intermediate position indication (configurable). A full list of available functions is provided in publication PUB002-040.

#### Analogue 4-20 mA position indication

Where the CPT option is fitted, a 4-20 mA signal is available for analogue position indication - refer to actuator circuit diagram.

#### Monitor relay

The monitor relay will indicate one or more of the following conditions:

- Loss of one or more of the power supply phases
- Loss of control circuitry supply
- Actuator selected for Local control or Local stop\*
- Thermostat tripped
- Internal failure

\* The monitor relay is configurable for Availability or Fault. If set to fault, the monitor relay will ignore the position of the Local / Stop / Remote selector. Refer to actuator circuit diagram for connections.

**Note: Indication outputs S1 to S4, Monitor Relay and the CPT analogue position signal do not fall within the scope of the actuator reliability assessment. The user must ensure the integrity of indication meets the requirements of the SIL target for the SIS. If necessary, limit position indication should be derived from certified devices external to the actuator and derived directly from the valve stem (obturator).**

### 3.6 Environmental

---

The environmental conditions in respect of enclosure rating, temperature, vibration (seismic and plant induced) etc. must not exceed those stated in the actuator specification. Refer to PUB002-038 for general information and the actuator nameplate and test certificate for details. Temperature range for applicable actuators is -40 to +70 °C. Operation outside these ambient temperatures will invalidate the safety assessment approval.

For hazardous locations, the actuator enclosure certification must meet the requirements of the location in respect of zone, gas group and temperature "T" rating. Refer to actuator nameplate.

### 3.7 Safety Instrumented System (SIS) Assessment for SIL 2 and SIL 3 Applications

The actuator is fit for use in a SIS requiring SIL 2 in a 1oo1 configuration for Safety Function 1 - Stayput providing the instructions contained in this manual are fully implemented. It is the responsibility of the SIS design engineer to carry out an overall SIL calculation of the SIS. The IQ3 is also suitable for use in a SIL3 application in a 1oo2 configuration.

#### Notes:

1. It is the responsibility of the system integrator to ensure that sufficient independence between the IQ3s in redundant mode is achieved to eliminate any common cause failure due to a single, common power supply or motor enable signal.
2. The PFD calculation shown in this section for redundancy mode uses a beta factor of 5% assuming a complete independent functionality of each IQ3 is configured.
3. The product systematic capability is SC3. In accordance with IEC 61508 part 2 clause 7.4.3, the maximum systematic capability that can be claimed is SC3 for a redundant system having satisfied the requirement of independence as detailed above.
4. Any installation, setup or calibration of a redundant system should be carried out independently. E.g. maintenance of one IQ3 should be carried out and completed before starting the other.
5. In a redundant system, padlocking of the control selectors of hand/auto lever should be achieved with independent padlock and key for each IQ3.

Data in the table below is only applicable for 1oo2 actuator configurations.

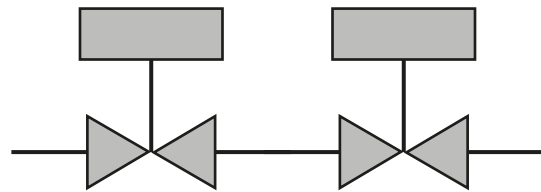

Fig 1. 1oo2 – Process Valve Isolation

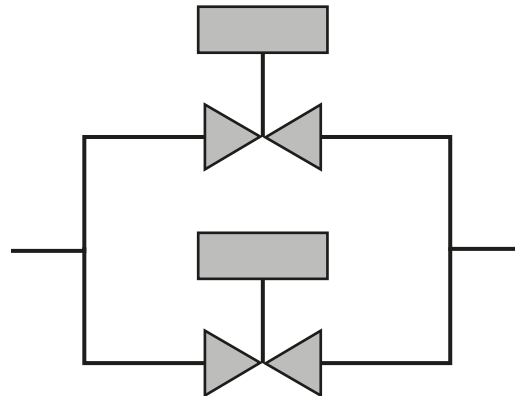

Fig 2. 1oo2 – Process Valve Bypass

#### IQ3 / IQ3 Pro:

Parameter	Size 1	Size 2	Size 3	Size 4	Size 5
<b>1oo1</b>					
Proof Test Interval (Hours)	8760	8760	8760	8760	8760
Type A/B	Type A	Type A	Type A	Type A	Type A
Safe Failure Fraction	93%	93%	93%	97%	97%
PFH	9.84E-07	9.84E-07	9.84E-07	9.28E-07	9.28E-07
SIL Capability (High/Continuous Demand Mode)	SIL2	SIL2	SIL2	SIL2	SIL2
<b>Parameter</b>	<b>Size 1</b>	<b>Size 2</b>	<b>Size 3</b>	<b>Size 4</b>	<b>Size 5</b>
<b>1oo2</b>					
Proof Test Interval (Hours)	8760	8760	8760	8760	8760
Type A/B	Type A	Type A	Type A	Type A	Type A
Safe Failure Fraction	96%	96%	96%	99%	99%
PFH	1.07E-07	1.07E-07	1.07E-07	1.00E-07	1.00E-07
SIL Capability (High/Continuous Demand Mode)	SIL2	SIL2	SIL2	SIL2	SIL2

#### IQT3 / IQT3 Pro:

Parameter	Size 1	Size 2	Size 3	Size 4	Size 5
<b>1oo1</b>					
Proof Test Interval (Hours)	8760	8760	8760	8760	8760
Type A/B	Type A	Type A	Type A	Type A	Type A
Safe Failure Fraction	96%	96%	96%	96%	96%
PFH	4.46E-07	4.46E-07	4.46E-07	4.46E-07	4.46E-07
SIL Capability (High/Continuous Demand Mode)	SIL2	SIL2	SIL2	SIL2	SIL2
<b>Parameter</b>	<b>Size 1</b>	<b>Size 2</b>	<b>Size 3</b>	<b>Size 4</b>	<b>Size 5</b>
<b>1oo2</b>					
Proof Test Interval (Hours)	8760	8760	8760	8760	8760
Type A/B	Type A	Type A	Type A	Type A	Type A
Safe Failure Fraction	96%	96%	96%	96%	96%
PFH	2.40E-08	2.40E-08	2.40E-08	2.40E-08	2.40E-08
SIL Capability (High/Continuous Demand Mode)	SIL3	SIL3	SIL3	SIL3	SIL3

## 4. Installation

**IMPORTANT:** All installations must be carried out by an appropriately trained or competent person, in accordance with any local electrical, health & safety and hazardous area legislation. Refer to publication PUB002-039 (IQ) or PUB002-065 (IQT) for safe use, installation and maintenance instructions.

It is the responsibility of the end user to ensure the commissioning engineer is trained in Functional Safety to a suitable level.

## 4.1 Important Information

**Commissioning must be completed and/or verified under any of the following circumstances:**

- When the actuator is installed on to the valve for the first time
- When valve & actuator are installed into the process for the first time
- When the actuator has been mechanically disconnected from the valve for any reason
- When the actuator has been physically disconnected from the electrical supply

The following table provides the necessary commissioning steps, in the order that must be followed, with the relevant section of instruction and the responsible organisation (or their nominated agent):

Step	Instruction	Responsibility
1	Set basic actuator settings (Section 4.3)	Valvemaker / End User
2	Verify valve setup (Section 5.1)	Valvemaker / End User
3	Verify basic actuator settings (Section 4.3)	End User
4	Set secondary actuator settings (Section 4.7 and 4.8 (if applicable))	End User
5	Safety Function Commissioning (Section 5.2)	End User

## 4.2 Basic Commissioning – Valve Settings

The following procedures must be followed in order. The configuration must be set as specified by the valvemaker/supplier and/or the responsible design engineer.

The setting tool is provided to make settings. For instructions on how to connect to an actuator using the Setting Tool, please refer to PUB002-039 (IQ) or PUB002-065 (IQT).

### Commissioning

All actuator settings, datalogger and asset management data is accessed using the supplied Rotork Bluetooth® Setting Tool *Pro* (BTST). Status and alarm data in addition to that shown on the home screen can also be accessed.

**⚠ WARNING: THE CONTROL COVER MUST NOT BE REMOVED; NO USER CONFIGURABLE SETTINGS ARE AVAILABLE WITHIN THE CONTROL ENCLOSURE. THE CONTROL COVER IS SEALED BY A QUALITY LABEL WHICH IF BROKEN MAY INVALIDATE WARRANTY.**

This instruction details the basic settings that must be completed before the actuator is put into service.

**⚠ WARNING: ELECTRICAL OPERATION MUST NOT TAKE PLACE UNTIL THE BASIC SETTINGS HAVE BEEN MADE AND CHECKED.**

The basic settings affect the correct operation of the valve by the actuator. If the actuator has been supplied with the valve, the valvemaker or supplier may have already made these settings.

Settings and operation must be verified by electric operation and function test of the actuated valve.

For instruction on control and indication settings and for information on diagnostics refer to PUB002-040.

Rotork Setting Tool incorporating Bluetooth wireless technology (Rotork Bluetooth® Setting Tool *Pro* – BTST) is shown below. It is identified by the key symbols being clear and a clear seal between the top and bottom casings.

The Infra-red only tool has filled yellow keys and a yellow seal between casings.

The Rotork Bluetooth® Setting Tool *Pro* with the relevant navigation and configuration keys is shown below.



The default security level for connecting to the actuator is by infra-red Bluetooth initiation. This requires that the user is at the actuator within 0.25 metre distance and in direct line of sight of the display.

Point the setting tool at the actuator display window and press key.

**The Setting Tool will automatically connect using Bluetooth which takes up to 5 seconds and when connected will be indicated by blue lights illuminating on the tool and in the actuator display window. Once connected, the tool can be used without pointing it at the actuator display window.**

Bluetooth connection will be maintained while setting tool key commands are made. After a period of 6 minutes with no key commands, Bluetooth connection will be turned off, the setting tool and display blue lights will go out. To manually turn off Bluetooth connection at any time, press the and keys together.

All actuator settings can be viewed with the actuator selected to Local, Stop or Remote.

## 4.2 Connecting to the Actuator *continued*

To change an actuator setting, the actuator must be selected to Local or Stop and a correct password entered.

If the actuator is selected to Remote and a setting is selected, the following warning will be displayed:

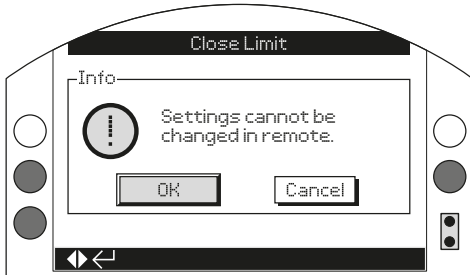

Select **OK** to return to settings screen.

With the actuator selected to Local or Stop and when any function is selected, the Password screen will be displayed:

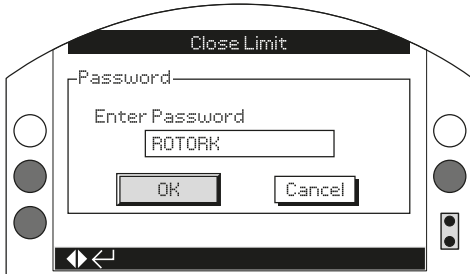

The factory set default password **ROTORK** is displayed and the **OK** key is highlighted.

Press the **OK** key.

The setting screen will again be displayed. The example below shows **Settings – Limits – Close** Settings with the function **Action** highlighted:

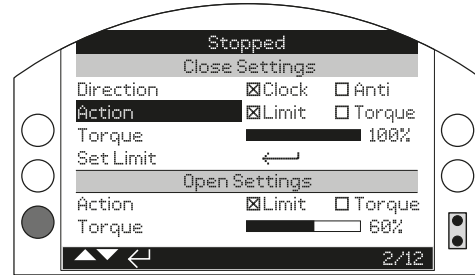

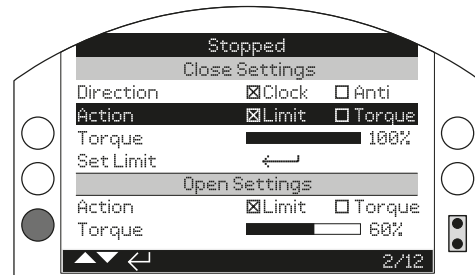

Press the **OK** key to select.

The function and its setting option or range will then be highlighted:



If the user does not wish to change the function value, press the back button to escape without changing.

## 4.2 Connecting to the Actuator *continued*

Use the  or  arrow keys to change the setting to the required value, the example below shows a close action of Torque having been selected:

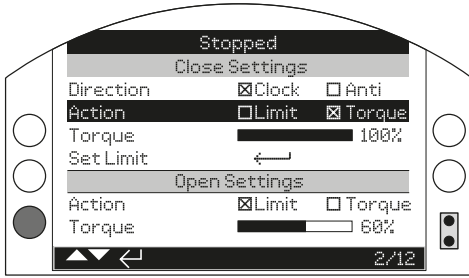

Press the  key to select.

The highlight will return to the function name only and its stored setting will be displayed:

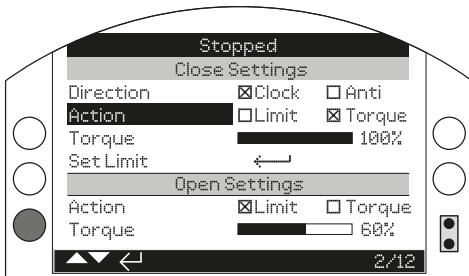

The password will be requested the first time a function is selected. Once correctly entered, the password will not be required to be entered again for the duration of setting tool communication with the actuator. Other functions can be set as required.

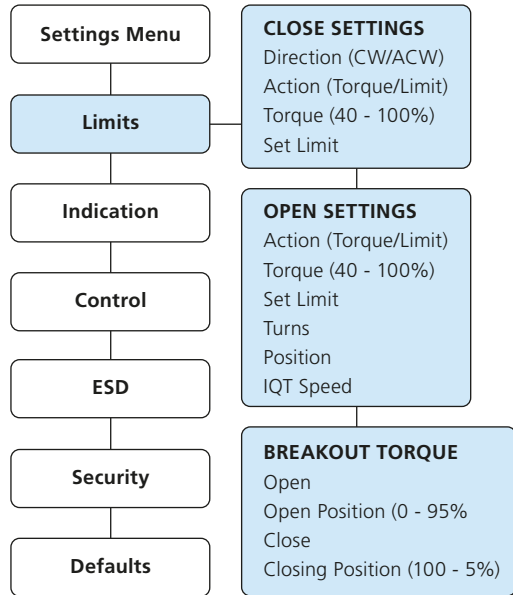

### 4.3 Basic Settings – Limits

**⚠ Settings and operation must be verified by electric operation and function test of the actuated valve.**

Connect to the actuator as described in Section 4.2. From the Position display home screen press the **⏏** key. The main menu will be displayed.

Navigate to **Settings** using the **⏏** **⏏** **⏏** **⏏** keys and press **⏏** to select.

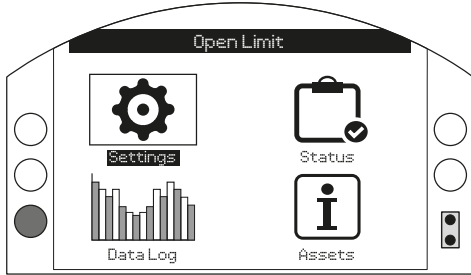

The settings menu will be displayed:

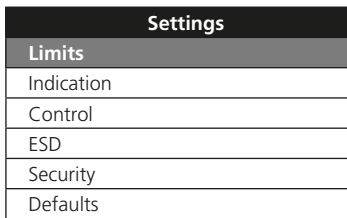

Navigate to **Limits** using the **⏏** **⏏** keys and press **⏏** to select.

**The setting first selected to be changed will require a password to be entered – refer to Section 4.2.**

The limit settings are shown below with their factory default values:

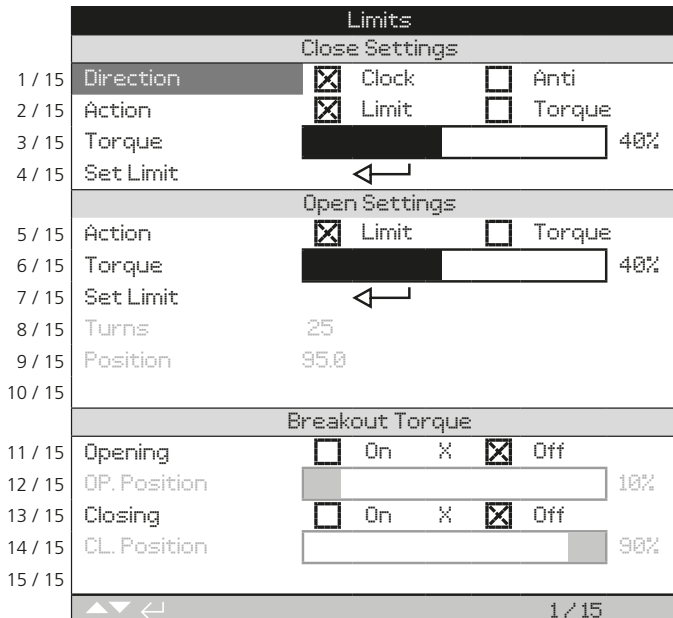

Function Close Direction (1/15) is shown highlighted. Use **⏏** **⏏** to scroll through functions. Functions will be highlighted in turn. Blank settings are IQT only.

### 4.4 Close Settings

#### 1 / 15 Close Direction

Function sets the direction required to close the valve. Manually operate the actuator and valve to establish closing direction.

Press **⏏** to select Close Direction function. Use **⏏** or **⏏** to check required setting.

Press **⏏** to set.

#### 2 / 15 Close Action

The actuator can be configured close on torque for seating valve types or limit for non-seating valve types.

**⚠ Refer to valve manufacturer for recommended setting. In the absence of valvemaker instruction refer to the following table.**

Valve Type	Close Action	Open Action
Wedge gate	Torque	Limit
Globe	Torque	Limit
Butterfly	Limit	Limit
Through Conduit	Limit	Limit
Ball	Limit	Limit
Plug	Limit	Limit
Sluice gate	Limit	Limit
Penstock	Limit	Limit
Parallel Slide	Limit	Limit

Press **⏏** to select Close Action function. Use **⏏** or **⏏** to check required setting.

Press **⏏** to set.

#### 3 / 15 Close Torque

The value of torque available to close the valve can be set between 40% and 100% of rated. The actuator rated torque value is shown on its nameplate.

Press **⏏** to select Close Torque function. Use **⏏** key to decrease value and **⏏** key to increase value.

Press **⏏** key to set.

#### 4 / 15 Set Close Limit

Press **⏏** to select Close Limit Function. The actuator will display the following instruction:

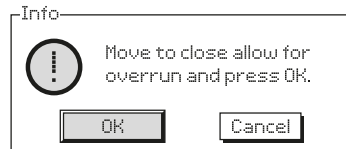

Move the actuator and valve to the close position. Allow for overrun by winding in the opening direction by 1/2 to 1 turn.

Press **⏏** to set the close limit position.



## 4.5 Open Settings

### 5 / 15 Open Action

The actuator can be configured open on torque for seating valve types or limit for non-seating valve types.

**⚠ Refer to Valve manufacturer for recommended setting. In the absence of valvemaker instruction set open action to "Limit".**

Press **⏸** to select Open Action function. Use **⏪** or **⏩** to check required setting. Press **⏸** to set.

### 6 / 15 Open Torque

The value of torque available to open the valve can be set between 40% and 100% of rated. The actuator rated torque value is shown on its nameplate.

Press **⏸** to select Open Torque function. Use **⏪** key to decrease value and **⏩** key to increase value.

Press **⏸** to set.

### 7 / 15 Set Open Limit

Press **⏸** to select Open Limit Function. The actuator will display the following instruction:

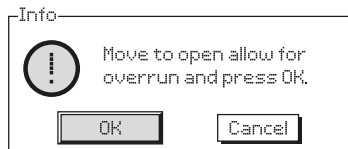

Move the actuator and valve to the open position. Allow for overrun by winding in the closing direction by ½ to 1 turn.

Press **⏸** to set the open limit position.

### 8 / 15 Turns (not editable)

Shows the actuator output turns between the set Closed and Open limit positions.

### 9 / 15 Position (not editable)

Shows the actuator current position in terms of % open.

**Note: Turns and Position values do not update while being displayed on screen. To see updated values, use **⏪** key to return to Settings Menu, then select Limits.**

## 4.6 Breakout Torque

The default setting for opening and closing breakout torque is Off (torque protection active at all times). Bypassing the torque protection allows torque up to approximately 150% of rated to be available. The valvemaker/integrator should be consulted to confirm the valve structure and interface components can withstand the additional torque/thrust.

### 11 / 15 Opening

Opening torque protection can be bypassed over a configurable portion of the opening stroke. When enabled, torque up to approximately 150% of rated torque is available for opening "sticky" valves.

Press **⏸** to select Opening Breakout Torque function. Use **⏪** or **⏩** to check required setting.

Press **⏸** to set.

### 12 / 15 OP position

When enabled (refer to 11 / 16), the position over the opening stroke where the torque protection is bypassed can be configured in the position range 0% (closed limit) to 95% open. Outside the bypass position, torque switch value will revert to that set, refer to 6 / 16.

Press **⏸** to select Opening Bypass Position function. Use **⏪** key to decrease value and **⏩** key to increase value.

Press **⏸** to set.

### 13 / 15 Closing

Closing torque protection can be bypassed over a configurable portion of the closing stroke. When enabled, torque up to approximately 150% of rated torque is available for closing the valve. Outside the bypass position, torque switch value will revert to that set, refer to 3 / 16.

Press **⏸** to select Closing Breakout Torque function. Use **⏪** or **⏩** to check required setting.

Press **⏸** to set.

### 14 / 15 CL position

When enabled (refer to 13 / 16), the position over the Closing stroke where the torque protection is bypassed can be configured in the position range 100% (open limit) to 5% open.

Press **⏸** to select Closing Bypass Position function. Use **⏪** key to decrease value and **⏩** key to increase value.

Press **⏸** to set.

#### 4.6.1 Verify Valve Operation (If the Process Allows)

Turn the red selector to LOCAL. Using the black selector, turn to the Close position and make sure the valve runs to the fully closed position. Check the correct seating action has occurred and the valve is fully shut.

Using the black selector, turn to the Open position and make sure the valve runs to the fully opened position. Check the correct seating action has occurred and the valve is fully open.

##### Return to Positional Display

Select REMOTE control using the red selector to exit setting procedure. If the procedure has been followed as described, the display will indicate open limit position (100%). Select Stop control.

#### 4.7 Secondary Settings – Remote Maintain (SF1 only)

**Note: Indication outputs S1 to S4, Monitor Relay and the CPT analogue position signal do not fall within the scope of the actuator reliability assessment. User must ensure the integrity of indication meets the requirements of the SIL target for the SIS. If necessary, position indication should be derived from devices external to the actuator and driven directly from the valve obturator.**

##### Monitor Relay

The monitor relay will indicate one or more of the following conditions:

- Loss of one or more of the power supply phases
- Loss of control circuitry supply
- Actuator selected for Local control or Local Stop\*
- Thermostat tripped

\*The monitor relay is configurable for Availability or Fault. If set to fault, the monitor relay will ignore the position of the Local / Stop / Remote selector. Refer to actuator circuit diagram for connections.

##### Contacts S1-S4

The actuator has four configurable contacts, S1 to S4 available for indication including open and closed position limit indication and intermediate position indication (configurable). A full list of available functions is provided in publication PUB002-040.

Unless specified with order, contacts S1 to S4 will be set to the default shown below:

Contact	Function	Contact
S1 [r1]	[CL] - Closed Limit	[NO] - Normally Open
S2 [r2]	[OP] – Open Limit	[NO] – Normally Open
S3 [r3]	[CL] - Closed Limit	[NC] – Normally Closed
S4 [r4]	[OP] – Open Limit	[NC] – Normally Closed

If fault coverage is required the 4 configurable relays can be set to operate as follows:

- Close limit
- Open limit
- Centre column rotating (indicates when the actuator is moving).
- Torque switch tripped (indicates the actuator has torque tripped mid travel and failed to reach the limit position).

##### Option CPT

If the CPT option is fitted a 4-20 mA signal is available for analogue position indication - refer to actuator circuit diagram. On loss of main actuator power supply, the CPT output will default to 0 mA regardless of actuator position.

## 5. Verification

For Safety Function 1 the permissive signal is applied using the remote maintain input terminal 34, which is remapped to become the Motor Enable input.

To keep the maintained / non-maintained feature during the remap, the user can select whether or not the remote control signals are self-maintained when the Motor Enable signal is present.

Navigate to the **CONTROL > REMOTE > HARDWIRED** menu:

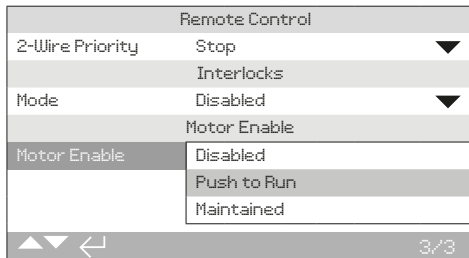
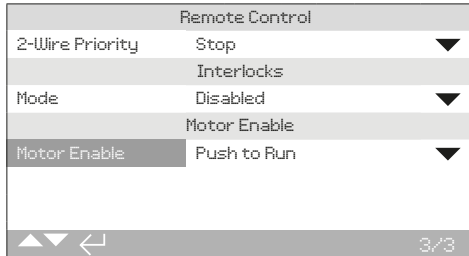

Navigate to the Motor Enable setting and press the **Ⓜ** key. From the drop down list select if Push to Run or Maintained control is required. Press the **Ⓜ** key to accept the setting.

## 5.1 Valve Setting Verification

It is important that actuator operation is verified to ensure the required safety function is achieved. In order to confirm actuator operation with the valve working under design conditions, it is desirable that the process is live during verification. Remote Open / Close and/or ESD / Motor Enable control circuits should be wired and available. Refer to actuator circuit diagram.

IQ and IQT actuators include a datalogger which records operational torque reference profiles for analysis of valve performance.

## 5.2 Safety Function 1 – Stayput Verification

1. Power up the actuator and select local control.
2. Operate the actuator in both open and close directions. Ensure the actuator operates the valve fully to each end of travel and the valve is positioned or seats correctly with the set action (torque or limit). If necessary, adjust basic settings, refer to Section 4.3

Torque profiles may be downloaded for analysis of actuator torque switch settings against operating torque requirements, refer to PUB002-040.

## 6. Tamper Prevention

Power up the actuator. Set the control selection and apply input signals as indicated in the following table to validate that the actuator will stayput unless the correct control selection is made and two valid signals are applied (open/close and motor enable):

SF1			
Control Mode	Applied Signal	Motor Enable Input	Action
Local	Open/Close	Applied	Local Operation
Local	Open/Close	Removed	Local Operation
Remote	Open/Close	Applied	Remote Operation
Remote	Open/Close	Removed	No Operation

Table 5.1

## 7. General Maintenance

Operation of IQ range actuators is described in publications PUB002-039 (IQ3 / IQ3 Pro) and PUB002-065 (IQT3 / IQT3 Pro).

When operating as part of the SIS the actuator is intended to be operated only by remote control and therefore should be selected and locked in "Remote". Overrides for Local control and Stop can be applied to ensure Safety Function operation is possible in these modes as well. Handwheel operation should also be prevented. Padlocks with a 6 mm / ¼" hasp should be used to padlock the red selector in the "Remote" position and the Hand-Auto lever in the neutral "up" position. Refer to Figure 6.1 and 6.2. These settings should be subject to the site operational procedures such as "permit to work".

**⚠ WARNING: If during commissioning, maintenance or testing the actuator is operated by the handwheel it is vital that it is returned to motor drive before the actuator is put back into operational service. To do this the actuator must be operated electrically and electrical operation verified by checking output movement. The hand auto lever must then be padlocked in the neutral "up" position.**



Fig 6.1. IQ / IQT control selector padlocked in "Remote"



Fig 6.2. IQ auto lever padlocked

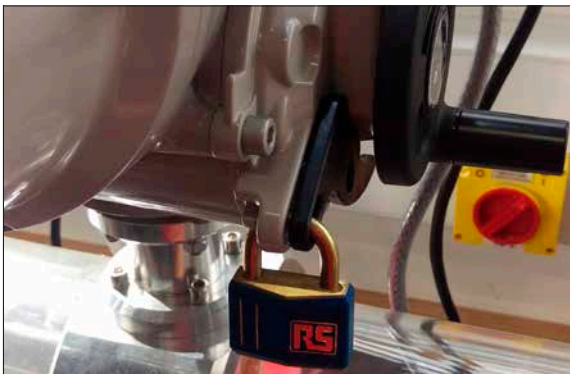

Fig 6.3. IQT hand auto lever padlocked

Refer to publication PUB002-039 (IQ3 / IQ3 Pro) or PUB002-065 (IQT3 / IQT3 Pro) for essential health and safety information.

When maintenance is to be carried out on or around an actuator it is essential that the actuator is electrically isolated to prevent unwanted operation.

Refer to publication PUB002-039 (IQ3 / IQ3 Pro) or PUB002-065 (IQT3 / IQT3 Pro) for information regarding actuator oil levels.

**⚠ WARNING: Isolate the actuator power supply before any work is carried out on the actuator, valve or associated system equipment or processes.**

**⚠ WARNING: The actuator is designed to perform the set Safety Function under system ESD conditions.**

## Notes

**Notes**

# rotork®



[www.rotork.com](http://www.rotork.com)

A full listing of our worldwide sales and service network is available on our website.

UK  
Rotork plc  
tel +44 (0)1225 733200  
email [mail@rotork.com](mailto:mail@rotork.com)

USA  
Rotork Controls Inc.  
tel +1 (585) 247 2304  
email [info@rotork.com](mailto:info@rotork.com)



PUB002-110-00  
Issue 08/23

As part of a process of on-going product development, Rotork reserves the right to amend and change specifications without prior notice. Published data may be subject to change. For the very latest version release, visit our website at [www.rotork.com](http://www.rotork.com)

The name Rotork is a registered trademark. Rotork recognises all registered trademarks. The Bluetooth® word mark and logos are registered trademarks owned by Bluetooth SIG, Inc. and any use of such marks by Rotork is under license. Published and produced in the UK by Rotork. POLTG0923